

Form WD 54

004440233

The Commonwealth of Massachusetts

No. 1391



Whereas, John K. Shank

of Oak Bluffs, in the County of Dukes and Commonwealth aforesaid, has applied to the Department of Environmental Quality Engineering for license to construct and maintain a pile-supported timber pier and timber mooring piles and has submitted plans of the same; and whereas due notice of said application, and of the time and place fixed for a hearing thereon, has been given, as required by law, to the Board of Selectmen of the Town of Oak Bluffs;

Now said Department, having heard all parties desiring to be heard, and having fully considered said application, hereby, subject to the approval of the Governor, authorizes and licenses the said

John K. Shank, subject to the provisions of the ninety-first chapter of the General Laws, and of all laws which are or may be in force applicable thereto, to construct and maintain a pile-supported timber pier and timber mooring piles in and over the waters of the Lagoon Pond in the Town of Oak Bluffs in conformity with the accompanying D.E.Q.E. License No. 1391 (2 Sheets)

License No. 1391

Bk: 444 Pg: 234

Page 2

A pile-supported timber pier shall be constructed and maintained extending into Lagoon Pond in a northwesterly direction for a distance of approximately 97 feet beyond the mean high water line.

Said timber pier shall have a deck width of 4 feet and shall have a finished deck elevation of 4.5 feet above the mean low water datum.

Two timber mooring piles shall be placed and maintained to the northeast of said pier in the locations shown on Sheet 1 of 2.

All work authorized hereby shall be performed in strict accordance with the Order of Conditions issued to said Licensee by the Town of Oak Bluffs Conservation Commission on August 9, 1985.

The Structures authorized hereby shall be limited to the following use: to provide the applicant with private noncommercial docking and for access to navigable waters.

All work authorized herein shall be in the location shown and in accordance with the details indicated on D.E.Q.E. License Plan No. 1391.

Please see page 3 for additional conditions to this license.

Duplicate of said plan, numbered 1391 is on file in the office of said Department, and original of said plan accompanies this License, and is to be referred to as a part hereof.

~~The amount of tide-water displaced by the work hereby authorized has been ascertained by said Department, and compensation thereof has been made by the said~~

Waterways License No. 1391

Bk 444 Pg 235

Page 3

STANDARD LICENSE CONDITIONS

1. Acceptance of this Waterways License shall constitute an agreement by the Licensee, to conform with all terms and conditions stated herein.
2. This License is granted upon the express condition that any and all other applicable authorizations necessitated due to the provisions hereof shall be secured prior to the commencement of any activity authorized pursuant to this License.
3. Any change in use or substantial structural alteration of any structure or fill authorized pursuant to this License shall require the issuance by the Department of a new License in accordance with the provisions and procedures established in Chapter 91 of the Massachusetts General Laws. Any unauthorized change in use or substantial structural alteration of any structure or fill authorized in this License shall render the License void. This License granted by the Department pursuant to this chapter shall be revocable for noncompliance with the terms and conditions set forth herein.
4. Nothing in this License shall be construed as authorizing encroachment in, on, or over property not owned or controlled by the Licensee, except with the written consent of the owner or owners thereof.
5. This License is granted subject to all applicable Federal, State, County, and Municipal Laws, ordinances and regulations.
6. This License is granted upon the express condition that use by boats or otherwise of the structure(s) and/or fill authorized hereby shall not involve any discharge of wastewater, sewage, petroleum products, or other polluting matter into adjacent waters, except in strict conformance with the requirements and authorizations of any applicable local and State health departments and the DEQE Division of Water Pollution Control.
7. This License is granted upon the express condition that the Licensee, its successors and assigns, shall upon request in writing by the Department, change the location of said _____ authorized herein, lower to such depth, raise it to such height, or remove it entirely from said waters, as the Department may prescribe. Said Licensee, by accepting this License, shall be deemed to consent and agree to this condition. In the case of refusal or neglect of a request by the Department on the part of the Licensee, its successors and assigns, to comply with this condition, the License shall be wholly void and the Commonwealth may proceed to remove or cause the removal of said _____ at the expense of said Licensee, its successors and assigns, as an unauthorized and unlawful structure and/or fill in said waters.

444236

License No. 1391

Page 4

by paying into the treasury of the Commonwealth
for each cubic yard so displaced, being the amount hereby assessed by
said Department.

Nothing in this License shall be so construed as to impair the legal rights of any person.

This License shall be void unless the same and the accompanying plans are recorded within
60 days
one year from the date hereof, in the Registry of Deeds for the
District of the County of Dukes

In Witness Whereof, said Department of Environmental Quality Engineering have hereunto
set their hands this Fourteenth day of March in the year
nineteen hundred and Eighty Six

Commissioner

Chief Engineer

Div. Director

Shank J.C.
Charles W. Nadeau
Gary R. Clayton

Department of
Environmental Quality
Engineering

THE COMMONWEALTH OF MASSACHUSETTS

This license is approved in consideration of the payment into the treasury of the Commonwealth
by the said John J. Shank
of the further sum of Four Hundred Dollars and No Cents (\$400.00)
the amount determined by the Governor as a just and equitable charge for rights and privileges
hereby granted in land of the Commonwealth. (200 square feet)

Approved by the Governor.

BOSTON,
[Signature]
Governor

Edgartown, Mass. March 25, 1986
at 1 o'clock and 51 minutes P.M.
Received and entered with Dukes County Deeds
book 444 Page 233.

Attest: *Sue W. King*
Register

Book 444 Page 236A

M.G.L. 36 SECTION 13A

I CERTIFY THAT THIS PLAN CONFORMS WITH THE RULES AND REGULATIONS OF THE REGISTERS OF DEEDS.

Glenn F. Provost

151 P
3/25/86

Vineyard Land Surveying
Box 1548 Norton Ave.
Vineyard Haven, MA 02568

SHEET 1 OF 2

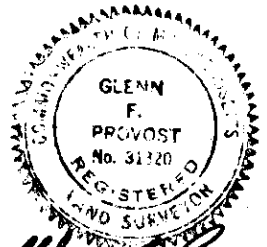

Glenn F. Provost
OCT. 11, 1984

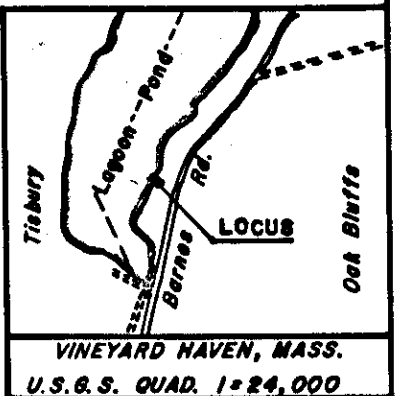

DATUM: M.L.W. = 0.0'
ELEVATIONS IN FEET

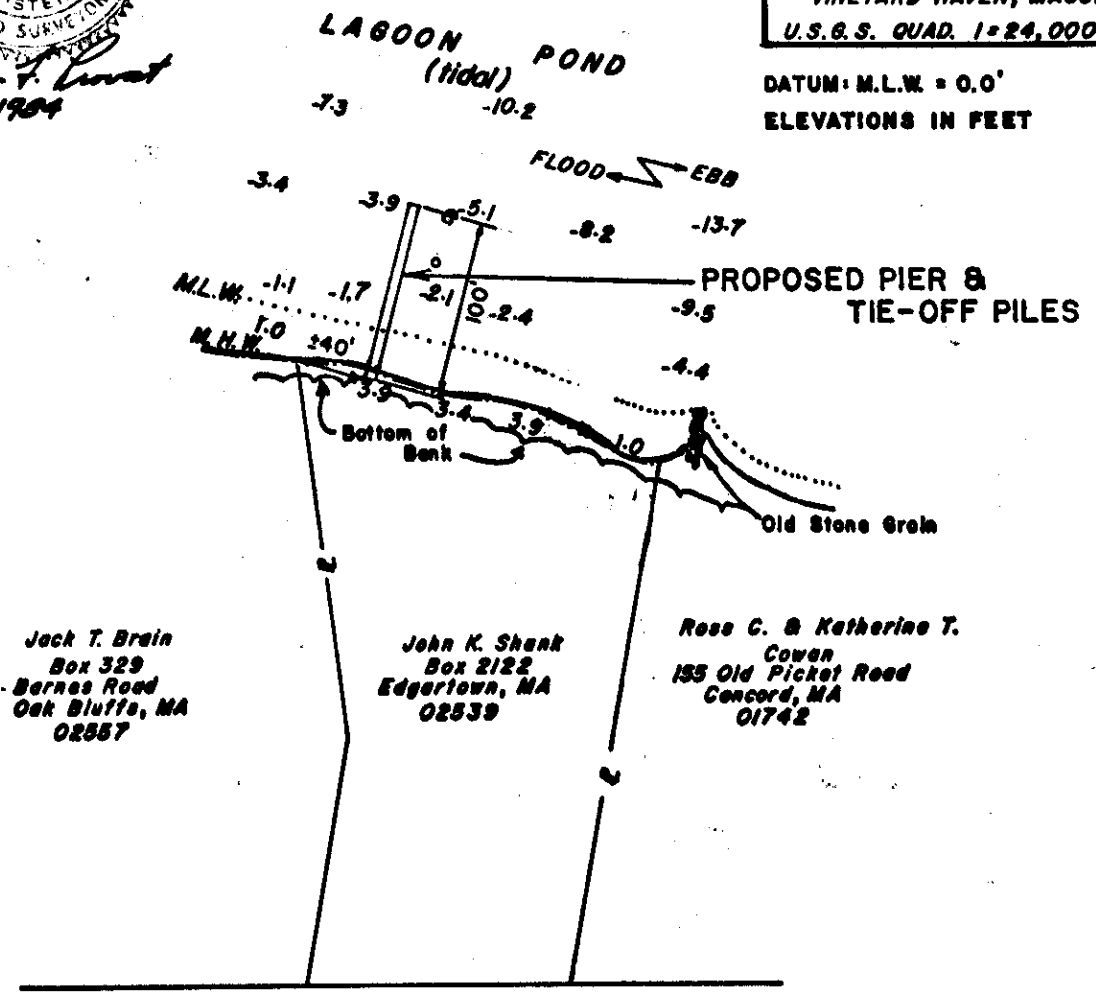

Jack T. Brain
Box 329
Barnes Road
Oak Bluffs, MA
02557

John K. Shank
Box 2122
Edgartown, MA
02539

Ross C. & Katherine T. Cowan
133 Old Picket Road
Concord, MA
01742

BARNES ROAD

PLAN
1 in. = 100 ft.
SCALE IN FEET

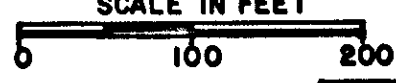

J.M. Forns d/b/a
APPLIED MARINE ECOLOGY LAB
Falmouth, Mass.

85W-183

PLAN ACCOMPANYING PETITION OF
John K. Shank
TO CONSTRUCT AND MAINTAIN A
TIMBER PIER & TIE-OFF PILES IN
LAGOON POND, OAK BLUFFS, MASS.
OCTOBER 9, 1984

LICENSE PLAN NO. 1391
Approved by Department of Environmental Quality Engineering
of Massachusetts
Edward M. L. COMMISSIONER
Charles W. ... CHIEF ENGINEER
Gary D. ... DIVISION DIRECTOR
14 MARCH 1986 DATE

Book 444 Page 236B

1.51 P

3/25/86

SHEET 2 OF 2

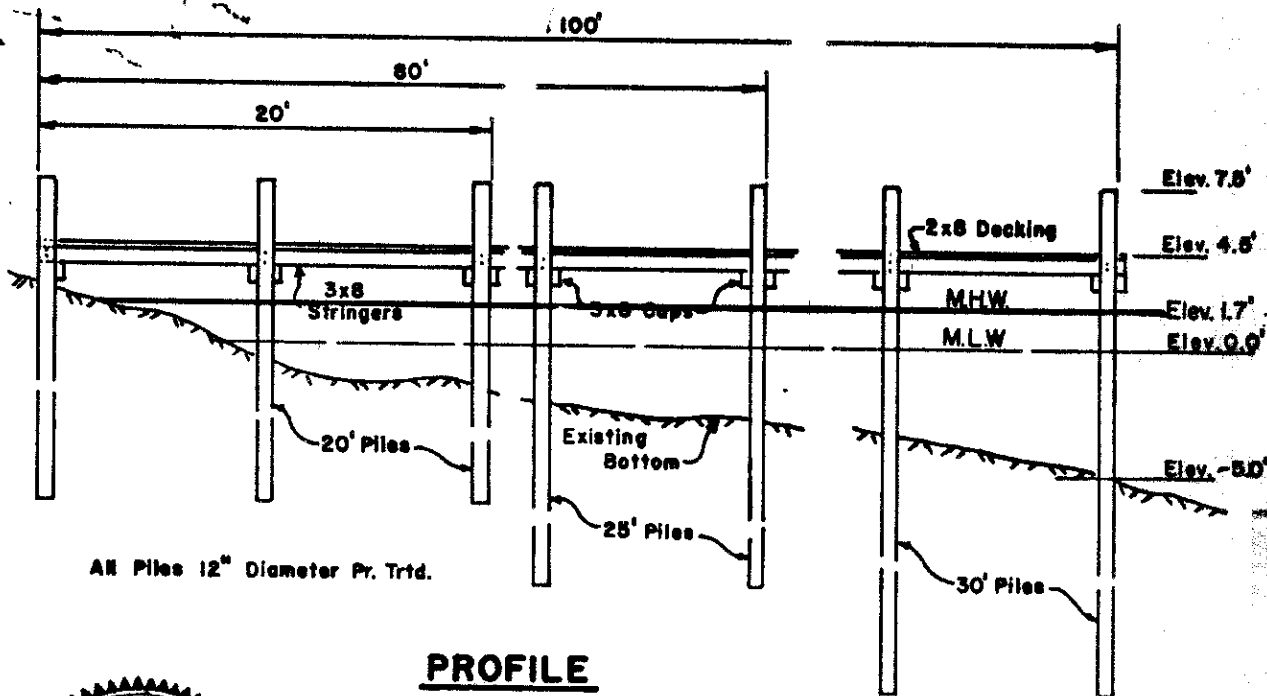

All Piles 12" Diameter Pr. Trtd.

PROFILE

SCALE: 1/8" = 1' 0"



STRUCTURAL REVIEW
FOR PERMIT PURPOSES ONLY
Kent A. Healy 10/10/1984

Cut at 15° and
Epoxy Resin Cover

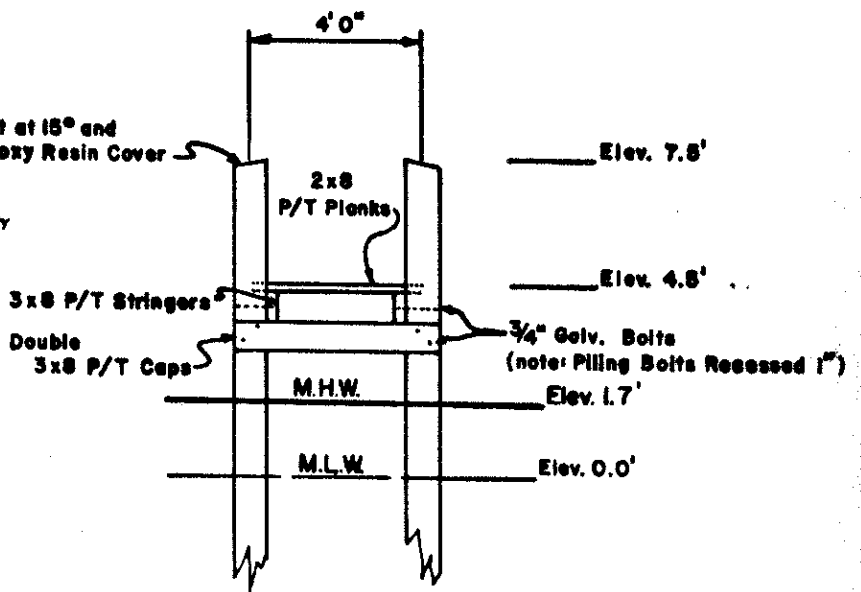

TYPICAL BENT SECTION

SCALE: 1/4" = 1' 0"

85W-183

J. M. Forns, APPLIED MARINE ECOLOGY LAB

John K. Shank

October 9, 1984

LICENSE PLAN NO. 1391

used by Department of Environmental Control & Planning

14 MARCH 1986